

RF-RR-T 24V Powered Routers/Temp Sensors



Features:

- Proven 802.15.4 low power network
- Complete range of sensor types
- Allows networks to be expanded

Benefits:

- Self-healing tree topology
- Lower installation costs
- Easy to install and commission

Technical Overview

These routers are used in conjunction with the Sontay RF-RX20 or RF-RX40 receiver units, and RF-RS series of battery powered radio sensors, and are used to route signals from battery powered nodes and other routers to the receiver module, where the signal strength of a direct path is not sufficient for reliable communications.

Note: Each router can support a maximum of 16 'children', which can consist of a maximum of 8 battery powered nodes and 8 routers, or up to 16 routers if there are no battery powered nodes. Consideration should be given to network planning for redundancy in case of router failure or damage.

Routers automatically find the best path back to the receiver, which may be directly to the receiver or via other 'parent' routers.

Tel: +44 (0)1732 861200. - E-mail: sales@sontay.com. - Web: www.sontay.com.

© 2012 Sontay Limited. All rights reserved

Specification:

Part Codes:

Common specification:

Radio Output:	
Frequency	2.4GHz
16 channels, automatically selected	
Direct-sequence spread spectrum	
Compliance	IEEE 802.15.4-2006
Data Encryption	AES 128
Power Output	+10dBm
Temperature accuracy	±0.3°C
Power Supply	24Vac/dc
Operating:	
Temperature	-10 to +50°C
RH	0 to 90%, non-condensing
Country of origin	UK

Plant Housing:

Material	ABS (flame retardant type VO)
Dimensions	116 x 106 x 52mm
Protection:	
Snap-shut lid	IP54
	IP65 (see page 4 note 8)
Probe material	Stainless steel (555, 632, 641, 651 & 631) PTFE (332)
Probe dimensions:	
(622 & 641)	150mm x 6mm dia.
(631)	10mm dia.
(632)	40 x 16mm dia. cable 2 meters
(555)	30 x 6mm dia. cable 2-5 meters
Aerial Characteristics:	
Gain	2.0dBi
VSWR	<2:1

Space Housing:

Material	ABS (flame retardant)
Dimensions	85 x 85 x 23mm
Protection	IP30
Aerial Characteristics:	
Gain	1.2dBi
VSWR	1.5:1



The products referred to in this data sheet meet the requirements of EU Directive 2004/108/E

RF-RR-T-911

Space temperature sensor/router

Options (for -911 only)

-MS	Momentary switch
-SP	Set-point adjust

RF-RR-T-622

Duct temperature sensor/router

RF-RR-T-642

Immersion temperature sensor/router

RF-RR-T-652

Clamp-on temperature sensor/router

RF-RR-T-631

Outside air temperature sensor/router

RF-RR-T-632

Outside air temperature with radiation shield sensor/router

RF-RR-T-555-2

Flying lead temperature sensor/router, 2m cable

RF-RR-T-555-5

Flying lead temperature sensor/router, 5m cable

How It Works:

Routers are used to route signals from battery powered nodes and other routers to the receiver module, where the signal strength of a direct path is not sufficient for reliable communications.

Data is transmitted back to the receiver at configurable time intervals, or on a configurable change in measured value. Each sensor retains these configurations if the battery becomes discharged or requires replacement.

The sensors, routers and receiver automatically select which of the 16 transmission channels available gives the best radio network performance, taking into account both signal strength and interference levels from adjacent channels and equipment (such as Wi-Fi etc.) The sensors and routers automatically find the best path back to the receiver, which may be directly to the receiver or via "parent" routers.

NB Each router can support a maximum of 16 "children", a maximum of 8 of which can be battery powered "end devices" and a maximum of which can be 8 routers. Consideration should be given on network planning for redundancy in case of router failure or damage.

Aerial Orientation (plant sensor types);

For best results ensure that the main body of the aerial is vertical.

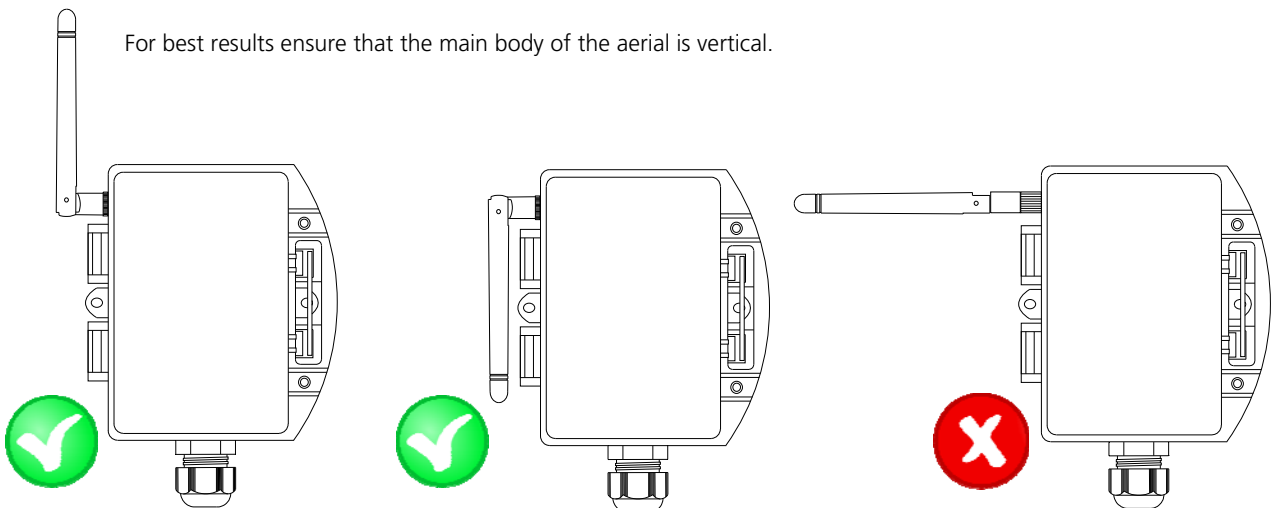

Installation:

Plant Sensor types:

1. Remove all packaging from the sensor.
2. Note the MAC address printed on the affixed label and note where this MAC address is installed.
3. Mount the sensor in the required position (this will have been determined by the site survey tool, (see the quick start guide and manual).
4. It is recommended that the unit be mounted with the cable entry at the bottom. If the cable is fed from above then into the cable gland at the bottom, it is recommended that a rain loop be placed in the cable before entry into the sensor.

Tel: +44 (0)1732 861200. - E-mail: sales@sontay.com. - Web: www.sontay.com.

© 2012 Sontay Limited. All rights reserved

Installation (continued):

5. See below for individual installation depending on sensor type.
6. Release the snap-fit lid by gently squeezing the locking tab and feed the cable through the waterproof gland & terminate the cores at the terminal block. Leaving some slack inside the unit, tighten the cable gland onto the cable to ensure water tightness.
7. Observe correct polarity if using a 24Vdc power supply. To power on the unit, fit J200.
8. Snap shut the lid after the connections have been made if IP65 protection is required, secure the lid with two screws provided.
9. Ensure, at a minimum, that all routers and the receiver on the radio network are powered on, and allow about 5 minutes for the network to auto-commission before attempting to read values or make configuration changes.

Duct

- Select a location in the duct where the sensor probe will give a representative sample of the prevailing air condition.
- Drill a 7mm diameter hole in the duct, then use the housing as a template mark the hole centres or use the dimensions below), drill and fix the housing to the duct with the screws supplied.

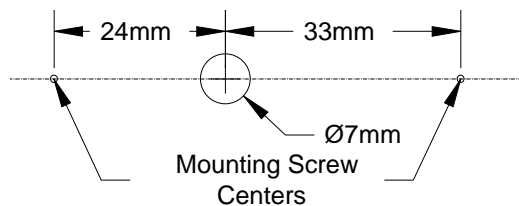

Immersion

- Select a location in the system where the liquid is to be measured, install pocket as per datasheet TT-PO.
- Insert the probe into the pocket and secure with the grub screw provided within the pocket.
- The immersion sensor must be used with a pocket; it is not designed for direct mounting.

Clamp-on

- Select a location in the system where the liquid temperature is to be measured, where the brass lug will make good contact with the surface of the pipe.
- Secure the brass lug to the surface to the pipe using the clip provided. Wrap the clip around the pipe and place the lug under the strap and tighten the clip. It is good practice to ensure that good contact is made between the lug and the pipe, and apply insulation over the pipe and lug.

Outside air

- Select a suitable location preferably on a north facing wall, ensuring that the sensor is away from direct sunlight and any heat sources.

Outside air with radiation shield

- Select a suitable location, the sensor has a radiation shield that helps minimize error gains from direct sunlight.

Tel: +44 (0)1732 861200. - E-mail: sales@sontay.com. - Web: www.sontay.com.

© 2012 Sontay Limited. All rights reserved

Installation (continued):

Space Sensor Types:

1. Remove all packaging from the sensor.
2. Note the MAC address printed on the affixed label and note where this MAC address is installed.
3. Mount the sensor in the required position (this will have been determined by the site survey tool, (see the quick start guide and manual).
4. Undo the tamperproof screw at the bottom of the housing and gently pull the front panel from the base.
5. Using the base as a template mark the hole centres and fix to the wall with suitable screws. Alternatively the base plate can be mounted on to a conduit box or a standard recessed back box.
6. Feed cable through the 22mm knockout in the base of the housing and terminate the cores at the terminal block as required. Leaving some slack inside the unit.
7. Observe correct polarity if using a 24Vdc power supply. To power on the unit, fit J200.
8. Replace the housing to the base plate.
9. Re-fit the tamperproof screw through the lug at the bottom of the base plate.
10. Ensure, at a minimum, that all routers and the receiver on the radio network are powered on, and allow about 5 minutes for the network to auto-commission before attempting to read values or make configuration changes.

Whilst every effort has been made to ensure the accuracy of this specification, Sontay cannot accept responsibility for damage, injury, loss or expense from errors or omissions. In the interest of technical improvement, this specification may be altered without notice.

Tel: +44 (0)1732 861200. - **E-mail:** sales@sontay.com. - **Web:** www.sontay.com.

© 2012 Sontay Limited. All rights reserved